



SHP-1560FPW

In-ceiling Housing



Key Features

- Enclosure : Aluminum / Top cover : Polycarbonate (PC)
- Dimensions : Ø268 x H209mm (10.55" x 8.23")
- Weight : 1,300g (2.87 lb)
- Color : White

SHP-1560FPW

In-ceiling Housing



Specifications

Mechanical

Color	White
Material	Enclosure : Aluminum Top cover : Polycarbonate(PC)
RAL code	RAL9003
Product dimensions / weight	Ø268x209mm (Ø10.55x8.23") / 1.3kg(2.87 lb)
Tile thickness	3~70mm
Conduit hole	19.1mm(3/4") (M25) 12.7mm(1/2") (M20)
Supported products	XNP-9250/8250/6400/9250R/8250R/6400R QNP-6250R/6320R ※ For further compatible models, please visit our website or use Toolbox

SHP-1560FPW

In-ceiling Housing



Unit: mm [inch]

CAD

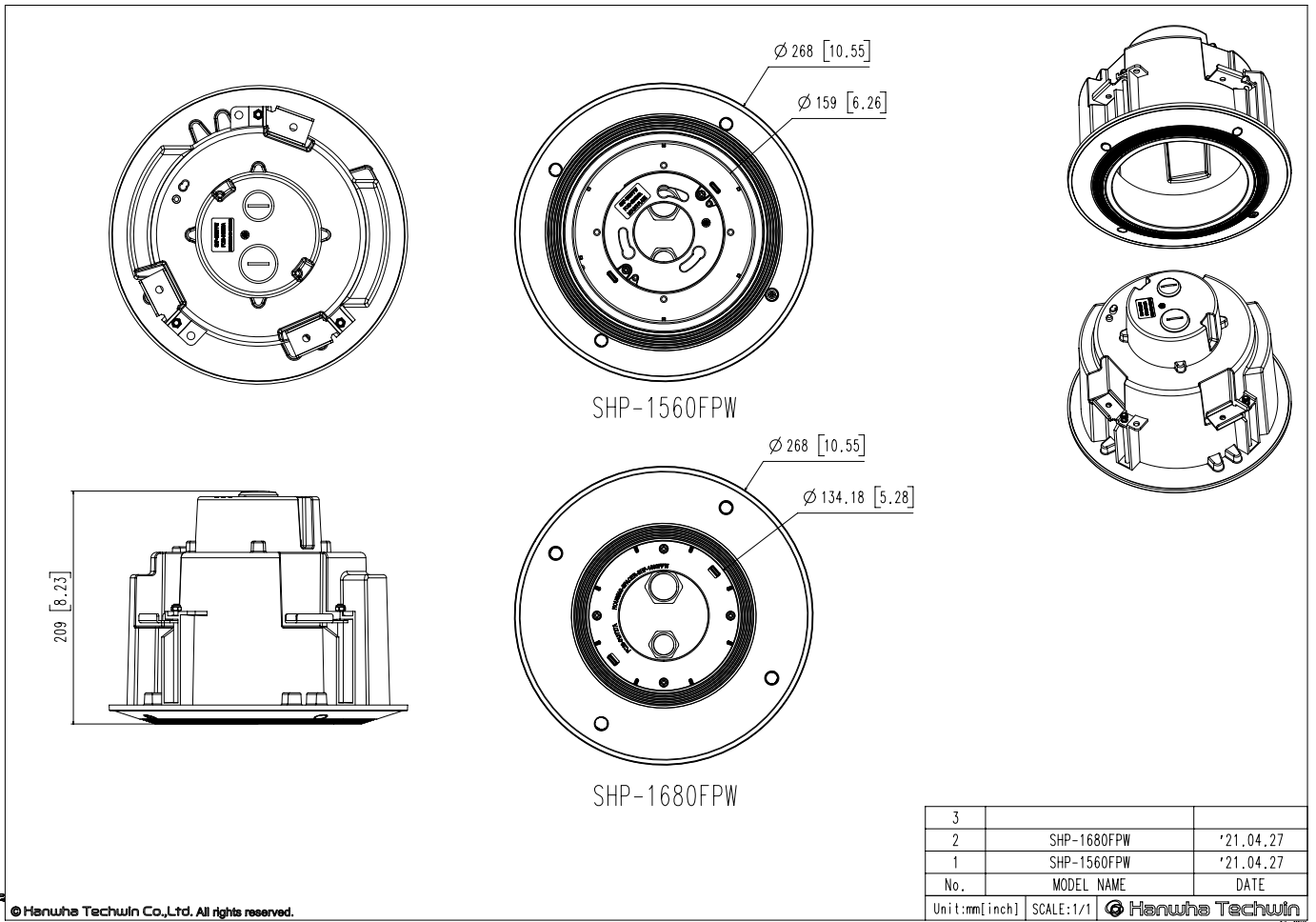

© Hanwha Techwin Co., Ltd. All rights reserved.